

Checkweigher VP-9000

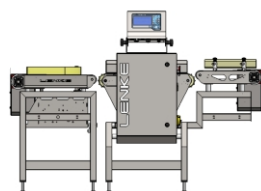
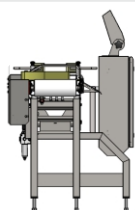

- 1g resolution
- 9000 unities/hour
- Strong construction
- Software to calibrate packing machines
- Products' final weight assurance

LENKE

www.lenke.com.br
www.lenkeautomacao.com.br

Checkweigher VP-9000

LENKE

Description:

The Checkweigher Lenke VP-9000 was developed to meet industry's need of assuring the real weight of commercialized products. Packing machines usually make mistakes and might undergo sudden decalibration. The VP-9000 efficiently assures this monitoring, thus avoiding damages to both the company and the customer.

Robustness:

Lenke VP-9000 is made out of the best available components and each part of the machine was designed considering continuous usage, in two or even three daily shifts. The equipment is made of stainless steel and non-corrodible materials. The machine perfectly stands cleaning procedures of the food industry.

Maintenance:

The equipment maintenance is simple and the project is compact, reducing components to the minimum necessary. The software interface is designed to make its use easy.

Technical Information

Dimensions: 1675 x 750 x 900 mm (L x W x H)

Construction: Stainless steel – AISI 304

Connectivity:

Serial: 2 × RS-232 bidirectional
Ethernet: 1 × IEEE 802.3, 10/100BASE-T
USB: 1 USB 2.0
I/O: 4 in y 4 out 24 VDC

Power supply:

Voltage: 80-240VAC 50-60 Hz
Compressed-air: 8 to 10 bar

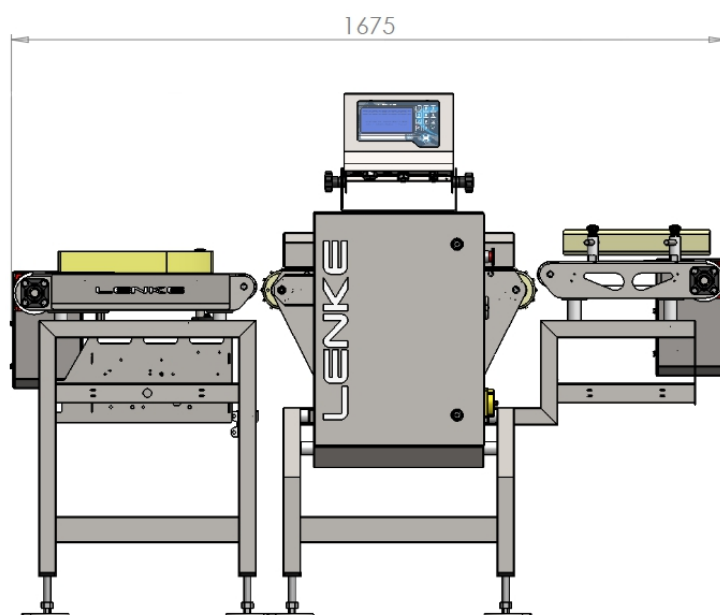
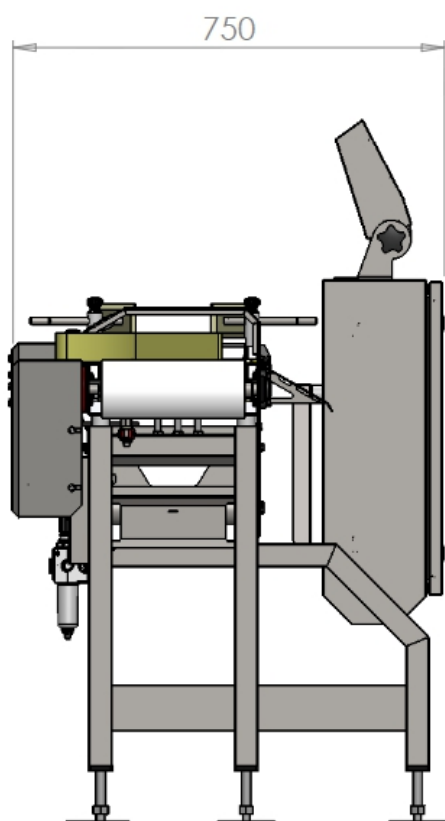

Tubarão-SC Rua Simeão Esmeraldino de Menezes, 400 SI.33 CEP 88704-090 Tel.: (48) 3301.4000

São Paulo-SP Rua Professor João Marinho, 193 CEP 04.007-010 Tel.: (11) 3884.4266

www.lenke.com.br

www.lenkeautomacao.com.br

comercial@lenke.com.br