

Checkweigher VP-1200

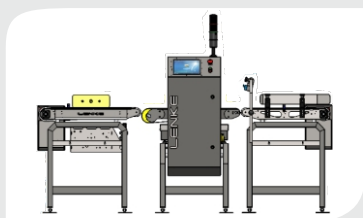
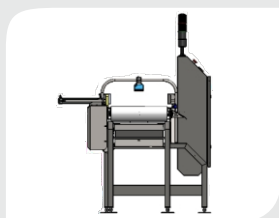
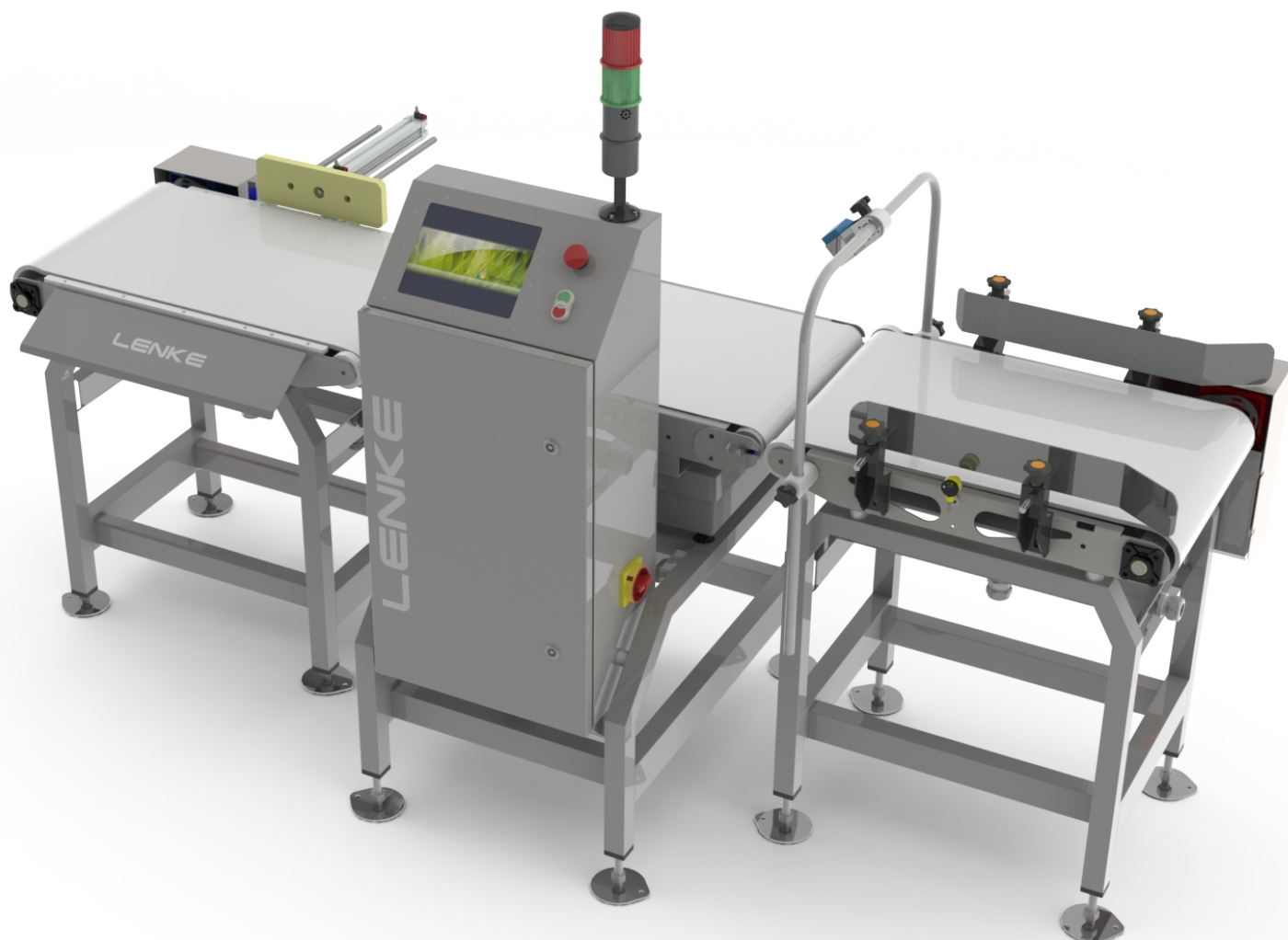

- 10g Resolution
- 20 unities/minute
- Strong construction
- Makes production recording
- Products' final weight assurance

LENKE

www.lenke.com.br
www.lenkeautomacao.com.br

Checkweigher VP-1200

LENKE

Description:

The Checkweigher Lenke VP-1200 was developed to meet industry's need of assuring the real weight of commercialized products and make the automatic production recording.

In the entrance conveyor, a static scanner reads a primary label on the package, thus identifies the product. The information is processed and each product has its weight tolerance. If the product meets the preset tolerances, the package is recorded in the client's database. Otherwise, the package is rejected and the recording is not executed.

The checkweigher efficiently assures this monitoring, thus avoiding damages to both the company and the customer.

Software:

The Lenke VP-1200's software has many resources in the standard version and allows customization according to the client's needs.

The production data are exported to client's database and allow clear visualization of what has been produced during certain period.

Accuracy and Productivity:

Lenke VP-1200 uses last generation technology for weighing and shows an accuracy of 10g, with standard deviation of 1 point. Lenke VP-1200 is capable of weighing up to 20 unities per minute. The maximum weight of the packages is 50kg.

Technical Information

Dimensions: 2367 x 1210 x 900 mm (L x W x H)

Construction:

Construction: Stainless steel – AISI 304
Protection Grade: Ip67

Connectivity:

Serial: 2 × RS-232 bi-directional
Serial: 1 × RS-232/422/485
Ethernet: 1 × IEEE 802.3, 10/100BASE-T
USB: 4 × USB 2.0

Power supply:

Voltage: 80-240VAC 50-60 Hertz
Compressed-air: 8 to 10 Bar

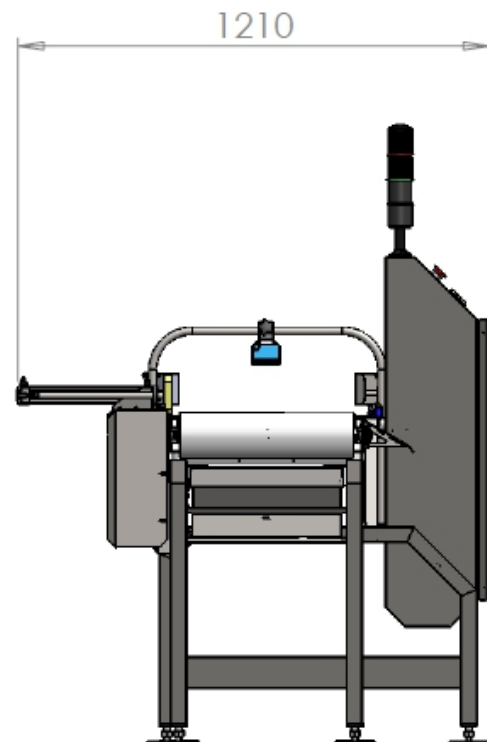
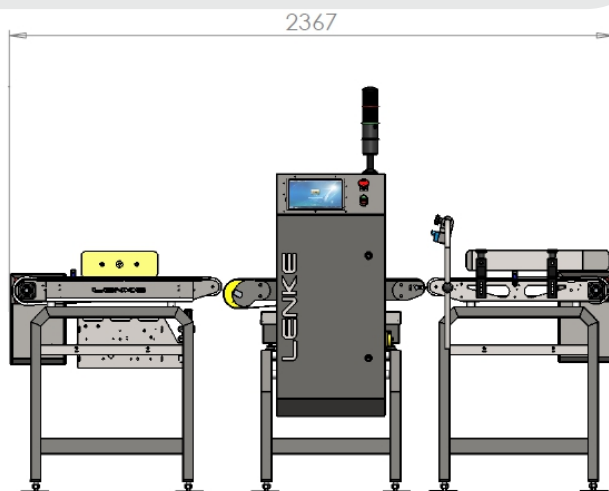

Tubarão-SC Rua Simeão Esmeraldino de Menezes, 400 SI.33 CEP 88704-090 Tel.: (48) 3301.4000

São Paulo-SP Rua Professor João Marinho, 193 CEP 04.007-010 Tel.: (11) 3884.4266

www.lenke.com.br

www.lenkeautomacao.com.br

comercial@lenke.com.br